

*The **ESPACE** and **RCB** range*

The new dimension
in cryoconservation



The Espace range

Your requirements are unbending where cryoconservation is concerned?

The ESPACE range meets your needs. Whatever the type of product, the quantity to be conserved or the storage system, there is an ESPACE that accurately matches your needs and will be able to change as they do.



ESPACE units are effective and easy-to-use too. Every detail has been thought out to make your work more pleasant and efficient.

But first and foremost ESPACE's technology is a guarantee of reliability. Because of the quality of the cryogenic compartment, as well as all the monitoring and control systems on the container, you are confidently able to store your most valuable products.

If your samples must not be in contact with liquid nitrogen, the ESPACE 151/331/661 GAS units are just for you. Off the floor, they are able to conserve in the gaseous phase throughout 100% of the storage capacity.

With the ESPACE range, enter the new dimension of cryoconservation.

EXTRAS THAT MAKE THE DIFFERENCE

Monitoring conservation

The level of the liquid and conservation temperature are clearly visible. The remote control interface is used to monitor and control the container remotely.

Ease of use

Access to conserved products is immediate because of the wide neck and rotating tray (except ESPACE 151, optional on ESPACE 331, standard on ESPACE 661).

Choice of attachments

The great variety of attachments enables the most specific needs to be met.

Safety

Samples can be conserved in the liquid or gaseous phase without reducing the storage capacity (ESPACE 151 331 / 661 GAS). The degassing system removes any risk of warm gas entering the container during filling.

Features	Espace 151 liquid	Espace 151 gas	Espace 331 liquid without casing	Espace 331 liquid with casing	Espace 331 gas without casing	Espace 331 gas with casing	Espace 661 liquid	Espace 661 gas
DIMENSIONS								
Useful capacity (l)	200	33	386		68		786	222
Access height (mm)	1205		1172				1355	
External height (mm)	1350		1310				1505	
External width (mm)	650		886	932	886	932	1150	
External depth (mm)	940		1100				1375	
Weight empty (Kg)	165		190	230	190	230	305	
Weight full without attachment (Kg)	326	192	505	545	245	285	920	465
Internal diameter (mm)	538		777 without rotating basket / 740 with rotating basket				1003	
Internal height (mm)	744		690				700	
CONSUMPTION								
Daily evaporation (l/d)*	6		9				11.5	
Static holding time (d)*	33	5.5	42		7		68	19

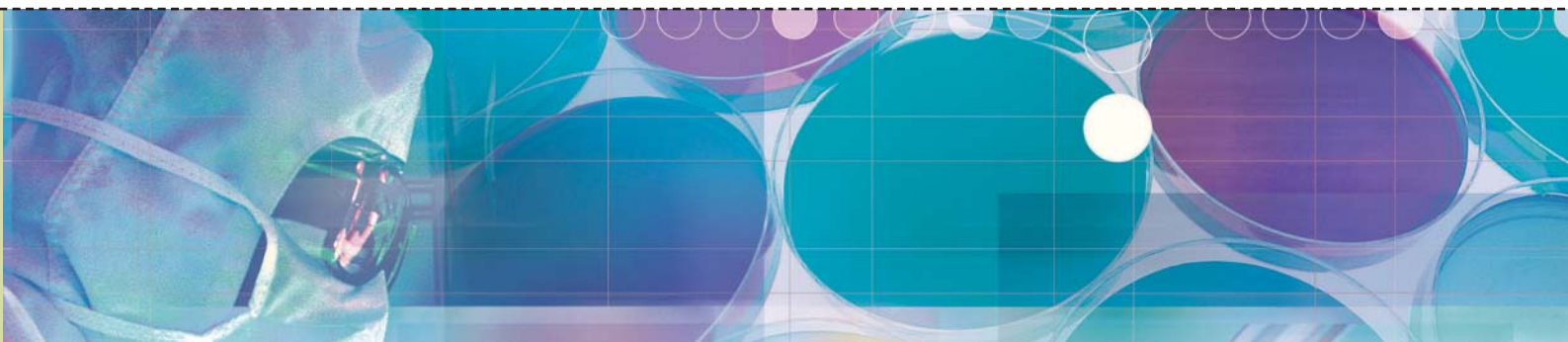

Features	Espace 151 liquid/gas	Espace 331 liquid/gas without rotating tray	Espace 331 liquid/gas with rotating tray	Espace 661 liquid/gas
2 ML VIALS				
Number of racks	7 (133x133 mm) + 4 (76x76 mm)	17 (133x133 mm) + 6 (76x76 mm)	15 (133x133 mm) + 6 (76x76 mm)	31 (133x133 mm) + 4 (76x76 mm)
Number of levels	13	12	12	12
Number of vials per boxe	25 / 81 ou 100			
Total capacity 2 ml vials	10400	22 200	19 800	38 400
5 ML VIALS				
Number of racks	7 (133x133 mm)	17 (133x133 mm)	15 (133x133 mm)	31 (133x133 mm)
Number of levels	7	6		
Number of vials per boxe	81			
Total capacity 5 ml vials		3969	8262	7290 15066
STRAWS IN CANISTERS				
Number of canisters	46	97	88	163
Number of levels	5			
Total capacity 0.25 ml	188 600	397 700	360 800	668 300
Total capacity 0.5 ml	83 950	177 025	160 600	297 475
Total capacity CBS 0.5 ml	51 750	109 125	99 000	183 375
STRAWS IN RACKS				
Number of racks 4 levels	7	17	15	31
Total capacity 0.25 ml	66 640	161 840	142 800	295 120
Total capacity 0.5 ml	23 800	57 800	51 000	105 400
Total capacity CBS 0.5 ml	16 660	40 460	35 700	73 780
BAGS				
Cryocyte 50 ml without holster	392	840	812	1568
Cryocyte 50 ml with holster	294	630	609	1176
Cryocyte 250 ml / DF200 without holster	192	432	400	800
Cryocyte 250 ml / DF200 with holster	144	324	300	600
Cryocyte 500 ml without holster	168	384	384	672
Cryocyte 500 ml with holster	140	320	320	560
DF700 without holster	120 ou 128	288	256	512
DF700 with holster	96	216 ou 240	192	384 ou 400

We have attachments optimised for most models from various manufacturers, just ask us.

The RCB range

An impressive volume for storage, reduced nitrogen consumption and unfailing sturdiness: for more than thirty years, RCBs have been the benchmark for containers in the cryobiology sphere.



RCBs 500/600/1000/1001 have a narrow neck that reduces nitrogen evaporation to the absolute minimum and conserves at an extremely low range of temperatures. They are also particularly suited for keeping large quantities of biological products for long periods.

For conservation in the gaseous phase, we have designed RCBs 600 and 1001 that enable contact between liquid nitrogen and samples to be avoided, without reducing the storage capacity.

RCBs can be fitted with an extremely wide range of internal attachments, which makes them suitable for a very broad variety of cryobiological applications. They also have the benefit of AIR LIQUIDE's extensive experience in monitoring and controlling cryoconservation.

Exceptionally reliable and robust, the RCB range gives you the guarantee of unfailing conservation.

EXTRAS THAT MAKE THE DIFFERENCE

Economical

The running cost is low because of the extremely low consumption of nitrogen.

Faultlessly fabricated from stainless steel, giving the container an exceptionally long life.

Easy to use

The assisted opening lid enables effortless handling . (option)

Choice of attachments

There are numerous possible configurations for internal attachments.

Monitoring conservation

RCBs can be fitted with any of AIR LIQUIDE's monitoring and control systems.

Safety

Samples can be kept in the gaseous phase throughout 100% of the container's storage capacity (RCB600 and RCB1001).

Features	RCB 500 liquid	RCB 600 liquid	RCB 600 gas	RCB 1000 liquid	RCB 1001 liquid	RCB 1001 gas
DIMENSIONS						
Useful capacity (l)	500	575	115	1020	1110	280
Access height (mm)	1260		1440	1300		1377
External height (mm)	1320		1500	1340		1440
External width (mm)	1100		1100		1320	
External depth (mm)	1200		1200		1400	
Weight empty (Kg)	250		270	415		445
Weight full without attachment (Kg)	654	735	337	1239	1641	671
Diameter of neck (mm)	461		461		601	
Internal diameter (mm)	850		850		1150	
Internal height (mm)	790	965	825	790	885	745
CONSUMPTION						
Daily evaporation (l/d)*	4.5		4.5		8	
Static holding time (d)*	111	127	18	127	105	36

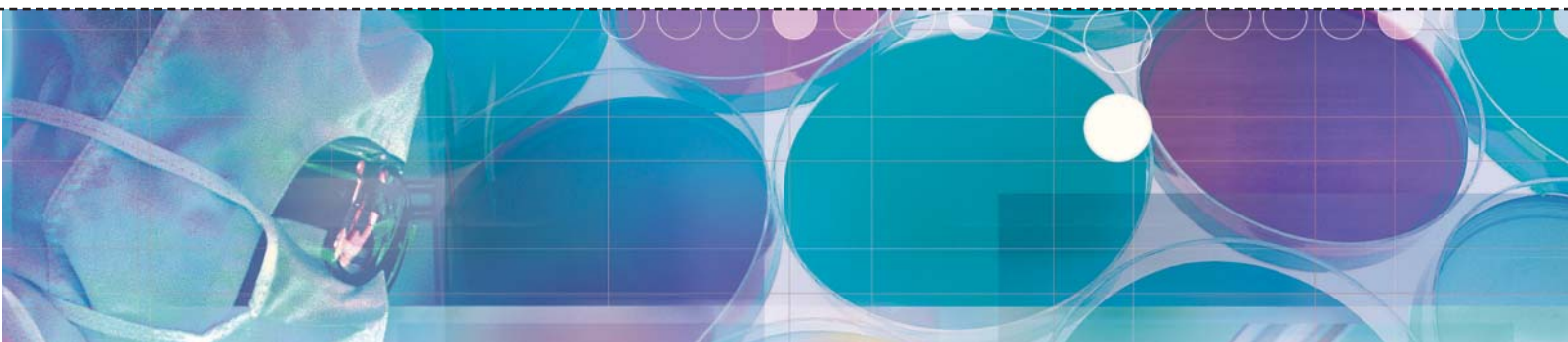

Storage capacity	RCB 500 liquid	RCB 600 liquid/gas	RCB 1000/1001 liquid/gas		
2 ML VIALS					
Number of racks	20 (133x133 mm) + 4 (76x76 mm)	20 (133x133 mm) + 4 (76x76 mm)	40 (133x133 mm)		
Number of levels	13	14	13		
Number of vials per boxe	25 / 81 ou 100		81 ou 100		
Total capacity 2 ml vials	27 300	29 400	52 000		
5 ML VIALS					
Number of racks	20 (133x133 mm)	20 (133x133 mm)	40 (133x133 mm)		
Number of levels	7	8	7		
Number of vials per boxe	81		81		
Total capacity 5 ml vials	11 340	12 960	22 680		
Storage capacity	RCB 500 liquid	RCB 600 liquid/gas	RCB 1000 liquid	RCB 1001 liquid without heighten	RCB 1001 liquid or gas with heighten
STRAWS IN CANISTERS					
Number of canisters	116	225			
Number of levels	5	6	5	6	5
Total capacity 0.25 ml	475 600	570 720	922 500	1 107 000	922 500
Total capacity 0.5 ml	211 700	254 040	410 625	492 750	410 625
Total capacity CBS 0.5 ml	130 050	156 600	253 125	337 500	253 125
Storage capacity	RCB 500 liquid	RCB 600 liquid/gas	RCB 1000/1001 liquid/gas		
STRAWS IN RACKS					
Number of racks 4 levels	20		40		
Total capacity 0.25 ml	190 400		380 800		
Total capacity 0.5 ml	68 400		136 000		
Total capacity CBS 0.5 ml	47 600		95 200		
BAGS					
Cryocyte 50 ml without holster	1008		1960		
Cryocyte 50 ml with holster	756		1470		
Cryocyte 250 ml / DF200 without holster	512		992		
Cryocyte 250 ml / DF200 with holster	384		744		
Cryocyte 500 ml without holster	432		864		
Cryocyte 500 ml with holster	360		720		
DF700 without holster	320		608		
DF700 with holster	240		456		

We have attachments optimised for most models from various manufacturers, just ask us.

Internal attachments

BAGS STORAGE

Bags are put in racks. The number of racks, levels and samples per level depends on the type of bag in order to optimise the attachment.

Bags can be put into individual protective holsters or directly stacked in the racks.

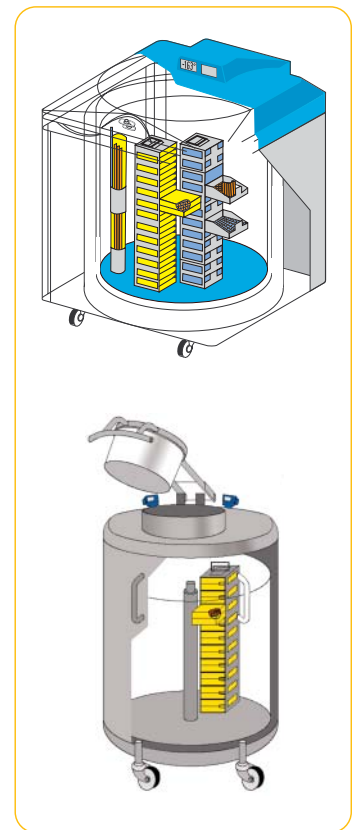
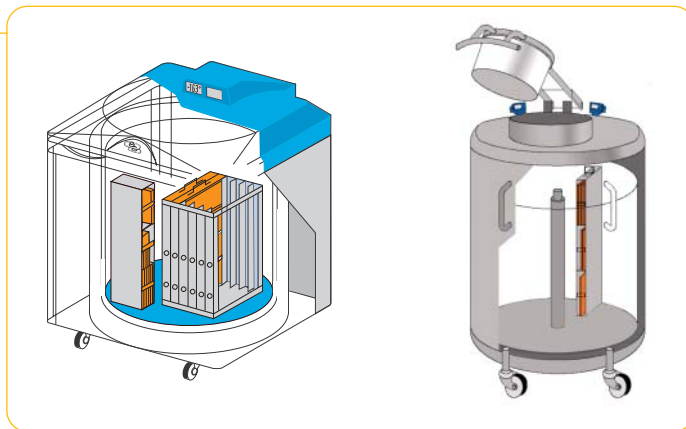

VIALS STORAGE

Two storage solutions:

- Storage in cryoplastic boxes. This is the most common system.

The boxes are put in metal racks. The individual locking of boxes in the rack eliminates the risk of them falling (AIR LIQUIDE patent system).

- Storage in canisters on vial-holder bars.

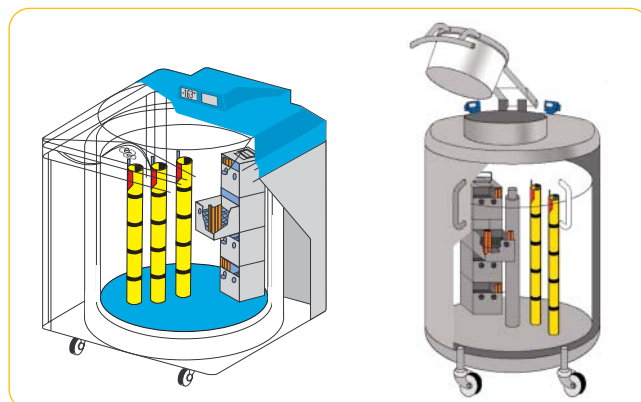

STRAWS STORAGE

Two storage solutions:

- Storage in canisters.

The straws are put in sight vials then in goblets stored in the canisters.

- Storage in racks with drawers. The straws are put into sight vials put in the drawers. AIR LIQUIDE exclusive system.



CONTAINER MONITORING AND CONTROL

Information about the conservation of samples is essential. The very wide choice of options described below undoubtedly makes the ESPACE and RCB ranges, the most innovative containers in their categories. First and foremost, they meet your real need for information and your requirements in terms of safety.

Device	Purpose	Standard	Optional
Temperature indicator	Continuously displays the temperature under the lid of the container. Alarm with adjustable trip point.	ESPACE	RCB
2 ^{ème} temperature indicator	Continuously displays the temperature of stored products. Alarm with adjustable trip point.		RCB ESPACE
Level indicator	Indicates the level of the liquid in the container. Alarm with adjustable trip point.	ESPACE	RCB
Automatic filling system	Connected to a source of liquid nitrogen, automatically fills the container. Integral upper and lower alarms.		RCB ESPACE
Manual filling button	It flushes the cloud of gas to allow total visibility on opening the container.		RCB ESPACE
Interface box for remote monitoring	For sending by wire all information provided by indicators and alarm signals. Ability to perform remote operations on the container.		RCB ESPACE
Automatic degassing system	Prevents warm gas from entering the container during automatic filling.		RCB ESPACE
THERMORY temperature traceability system	Enables the conservation temperature of samples to be recorded and processed.		RCB ESPACE
COOLBASE program	User-friendly database program for easy, sure, efficient management of products stored in one or more containers.		RCB ESPACE



Temperature indicator



Level indicator



Remote monitoring interface

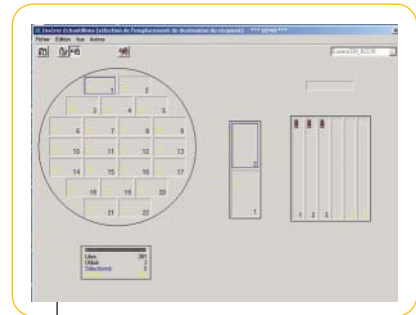

COOLBASE program

Contact

DIVISION MATÉRIEL CRYOGÉNIQUE
9, Parc Gustave Eiffel - 8, avenue Gutenberg
Bussy Saint-Georges
77607 Marne La Vallée Cedex 3 - France
Tel.: 33 (0)1 64 76 15 00 - Fax: 33 (0)1 64 76 16 99

See us at www.dmc.airliquide.com
ISO 9001 version 2000



Founded in 1902, world leader in gases for industry and medicine and associated services, Air Liquide operates in 65 countries and has 30,800 employees. Using constantly updated technologies, Air Liquide develops innovative solutions that contribute to the manufacture of numerous everyday and life-saving products.